



HANGCHA

HANGCHA GROUP CO., LTD.

(Zhejiang Hangcha Imp.&Exp.Co.,Ltd.)

www.hcforlift.com

Add:398 Shi Qiao Road, Hangzhou Zhejiang province, China(310022)

Factory site:No.88, Donghuan Rd., Economic Development Zone Lin'an, Zhejiang, China(311305)

Tel: +86-571-88926755

Fax: +86-571-88926789 88132890

E-mail: sales@hcforlift.com

HANGCHA GROUP CO., LTD. Reserves the right to make any changes without notice concerning colors, equipment, or specifications detailed in this brochure, or to discontinue individual models. The colors of trucks, delivered may differ slightly from those in brochures.

your local dealer

COPYRIGHT 2013.06

SFC HANGCHA



HANGCHA A series Electric trucks

MOVE FREELY, LIFT FREELY

MOVE FREELY, LIFT FREELY

HANGCHA A series Electric trucks

The new generation A series 1-3.5t electric truck is the new product based on the original products and own developed by HANGCHA. The totally new designed outline, comfortable operation and reliability are fully improved, and the whole truck's performance is also improved.





EXTERIOR



Applied advanced new designing method, world famous designing company designed, make the eye catchable stream outline of the truck chassis. Small dimension, simple appearance, and metal material applied for the exposed parts, all provide robust construction of the A series.



POWER TRAIN

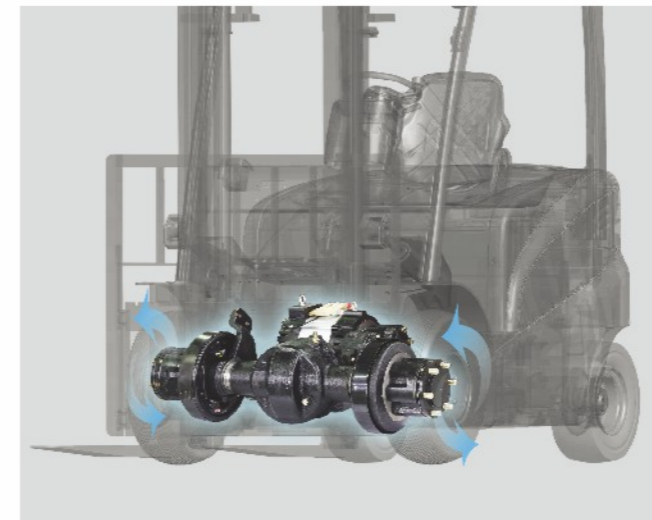

Advanced parallel layout of drive motor and lower located battery up to chassis bottom provide good stability to the truck.





Side battery change is available for heavy and long time application.

COMFORT

Low center of gravity provides good turning stability, and better operator's driving comfort. 150mm adjustable distance of seat provides better operator's comfort of different operators.

Soft landing system is applied for A series.

When the forks lower to 60-100mm to ground, the soft landing system is auto operated, and to avoid the forks dashing against the ground. New designed broad view mast provides better forward visibility.

Easy to see LED dashboard provides friendly interaction.

Low noise, no exhaust emission, and low energy consumption, all meet environment friendly requirement.



Ergonomic design cab, and parking brake meet ISO3691



150mm adjustable seat



Soft landing system

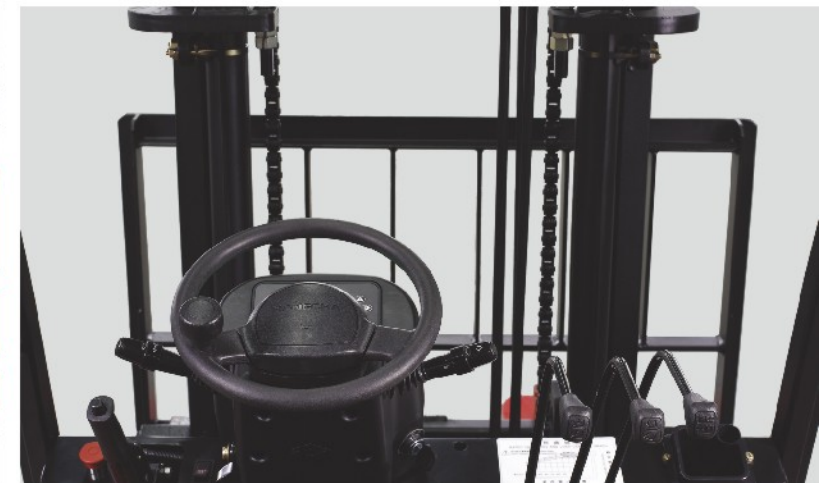

Broad view mast



Operation Compartment





ADVANCED

High frequency MOSFET controller provides accurate control of travelling, lifting, and better adjustable performance, and better matches the motor. Regenerative braking, reverse current braking and anti-slide on slope function guarantee the operation safety.

Multi functions big LED dashboard provides running hours, battery power, and self diagnosis functions, and with high accuracy even in bad environment.

Regenerative braking is more energy saving and efficiency during truck's deceleration, direction changing, and driving on downwards slope.

C3/C4 system

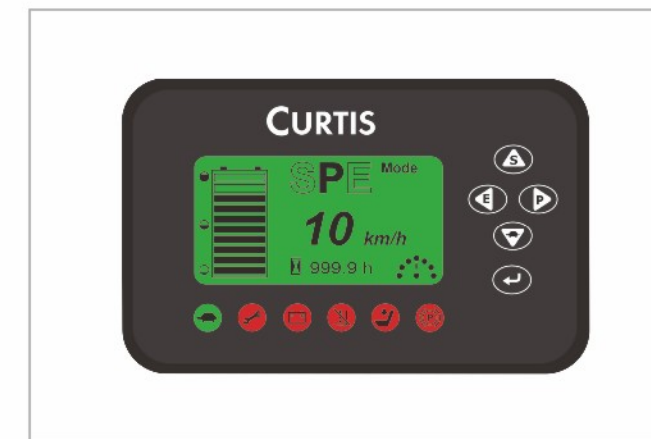

CURTIS big LED dashboard. Non-handset Operation



Imported high performance, and new generation AC controller

D2 system



Kollmorgen dashboard



Kollmorgen GEN6 controller

SERVICE ABILITY

Full open battery, easy for battery service
Easy opened counter weight cover, to protect internal controller to avoid water and dust
World famous brand electronics are applied in motor controller, contactor, power plug, emergency switch, dashboard, and accelerators.
Overloaded protection system is applied for electronics and hydraulics.
CE certificate is available.



Battery cover with auto lock spring for easy battery service and replacing, and clean the oil tank.



Side battery changing solution is applied for heavy and long time application.



Easy opened counterweight cover is to protect the internal controllers to avoid water and dust.



Big dimension anti-slip rubber pad.



CHINESE PATENTS



ZL201230432857.2

ZL03232699.8

ZL201020233942.1

ZL201020148198.5

ZL201120546780.1

ACCESSORY

STANDARD FEATURES	OPTIONS
High efficiency AC driving motor	Side way battery change
Special for truck's lifting motor	Big capacity Chinese made battery
Multi-functions dashboard	Cold store application
Full electronic controlled travelling, lifting and steering	High performance import battery
Front lighting system, turning indicator, LED combined three colors' rear lights	Battery charger
Big dimension rubber pad	Rear lighting system
Sheet metal stamping made front and rear bottom plate	Front dual tyre
Sheet metal stamping made left and right cover and battery cover	SE tyre
Standard battery	Non-marking tyre
Reversing beeper	Suspension seat with higher OHG
Full hydraulic steering	Left and right rear view mirror
Storage box	Reversing hand grip with horn button
Soft landing system	Wider fork carriage
Standard forks in red	Wide or higher load backrest
3m duplex mast	Other dimension forks
Tow coupling	Duplex mast with full free lift
Center located rear view mirror	Triplex mast
OPS1: Lock lifting, tilting, sideshifting...Lock traveling..	Integrated side shift
	Other attachments
	OPS2: Lock Lowing

COLOR



CAPACITY

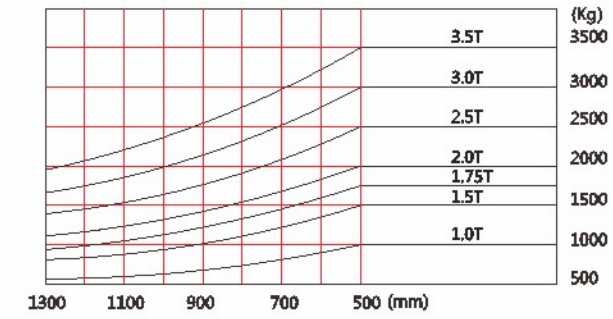

STRUCTURE

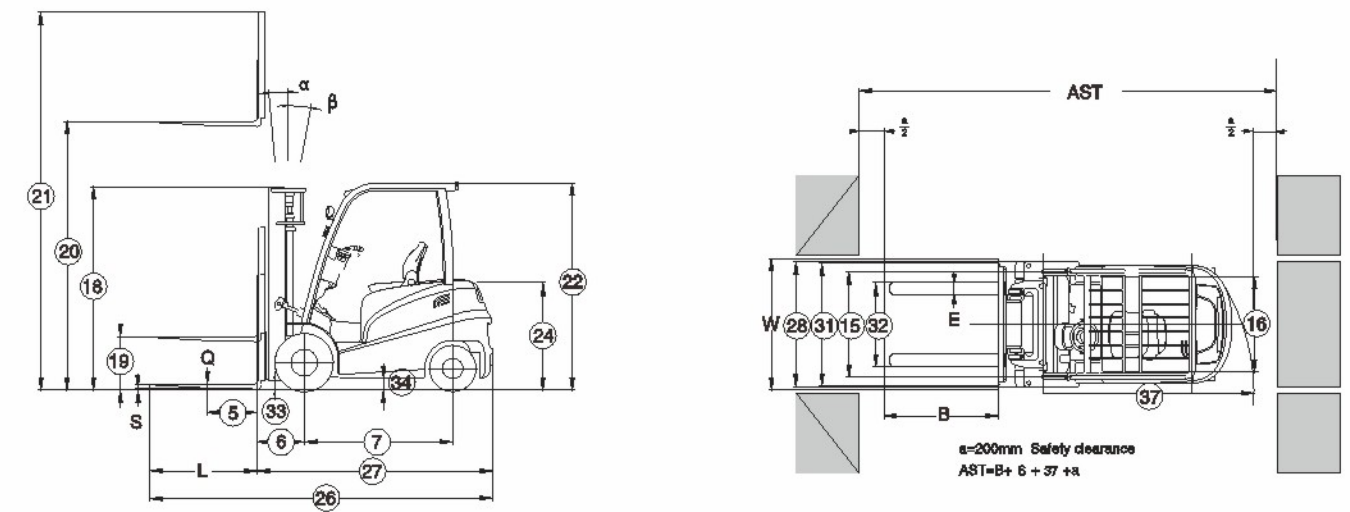

SPECIFICATION

Model	Rated Capacity (kg)	Load center (mm)	Drive	Std. Lifting Height(mm)	Length to face of forks (mm)	Overall Width (mm)	Overall Height (mm)
CPD10-AC3	1000	500	Electric	3000	2098	1120	1995
CPD10-AC4							
CPD10-AD2							
CPD15-AC3	1500	500	Electric	3000	2098	1120	1995
CPD15-AC4							
CPD15-AD2							
CPD18-AC3	1750	500	Electric	3000	2098	1120	1995
CPD18-AC4							
CPD18-AD2							
CPD20-AC3	2000	500	Electric	3000	2342	1265	2070
CPD20-AC4							
CPD20-AD2							
CPD25-AC3	2500	500	Electric	3000	2342	1265	2070
CPD25-AC4							
CPD25-AD2							
CPD25-ALC3	2500	500	Electric	3000	2482	1265	2100
CPD25-ALC4							
CPD25-ALD2							
CPD30-AC3	3000	500	Electric	3000	2502	1265	2100
CPD30-AC4							
CPD30-AD2							
CPD35-AC3	3500	500	Electric	3000	2582	1302	2100
CPD35-AC4							
CPD35-AD2							